



## System No. 25C FHIT.25C Electrical Circuit Integrity Systems

[Page Bottom](#)

### Design/System/Construction/Assembly Usage Disclaimer

- Authorities Having Jurisdiction should be consulted in all cases as to the particular requirements covering the installation and use of UL Certified products, equipment, system, devices, and materials.
- Authorities Having Jurisdiction should be consulted before construction.
- Fire resistance assemblies and products are developed by the design submitter and have been investigated by UL for compliance with applicable requirements. The published information cannot always address every construction nuance encountered in the field.
- When field issues arise, it is recommended the first contact for assistance be the technical service staff provided by the product manufacturer noted for the design. Users of fire resistance assemblies are advised to consult the general Guide Information for each product category and each group of assemblies. The Guide Information includes specifics concerning alternate materials and alternate methods of construction.
- Only products which bear UL's Mark are considered Certified.

### FHIT - Electrical Circuit Integrity Systems

[See General Information for Electrical Circuit Integrity Systems](#)

## System No. 25C

November 08, 2016

**Fire Rating - 2 Hr.**

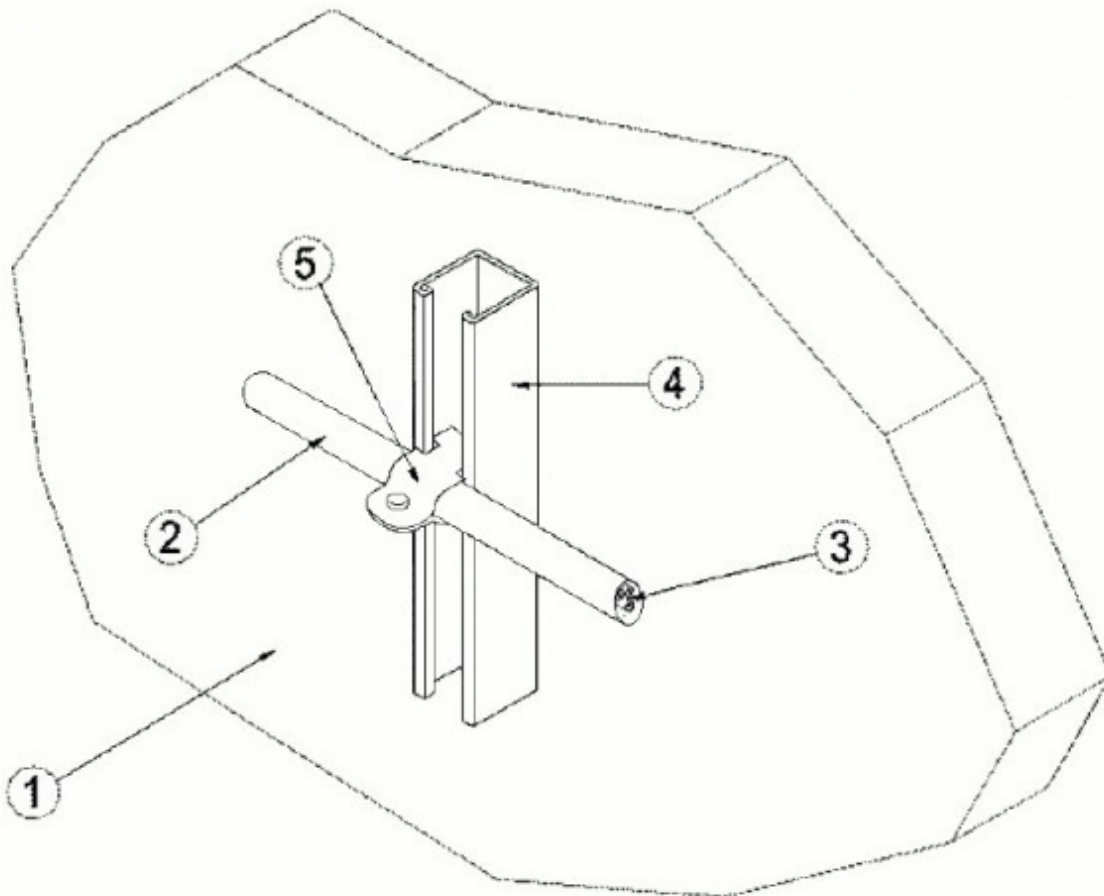

Fig. 1  
Two-piece Single-bolt Pipe Clamp

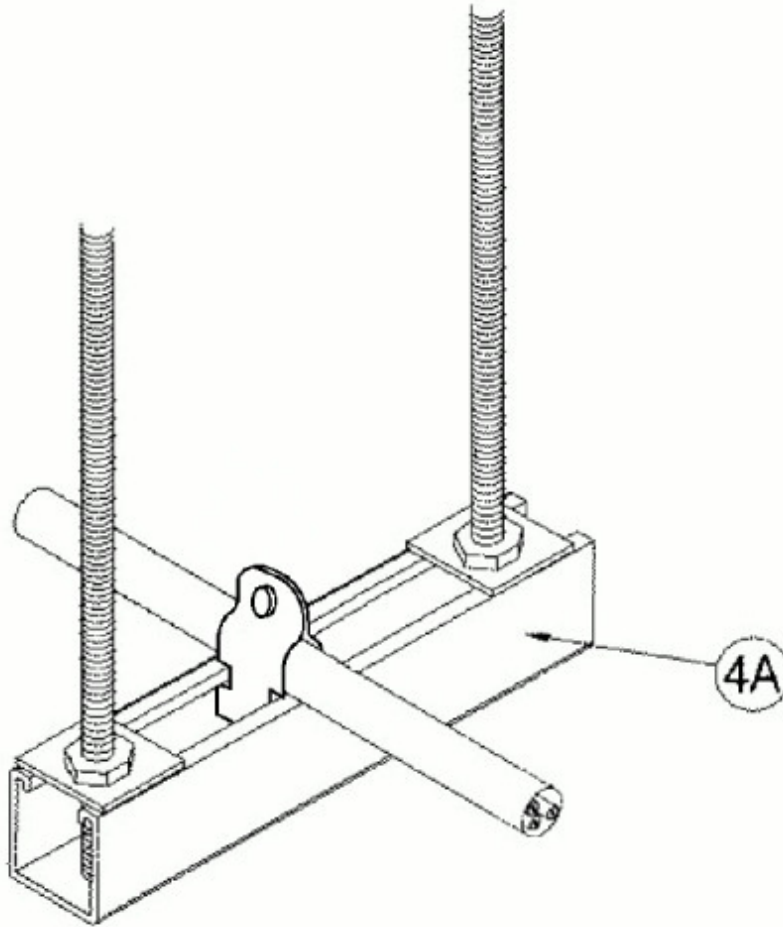

Fig. 2  
Steel Strut Trapeze

1. **Wall or Floor Assembly\*** — Minimum 2 hour fire rated concrete or masonry wall or concrete floor. Opening in wall or floor through which raceway passes is to be sized to closely follow the contour of the raceway. Through opening in wall or floor to be firestopped using a compatible firestop system.

See **Through-penetration Firestop Systems** (XHEZ) category for presently Certified firestop systems.

2. **Raceway\*** — Reinforced Thermosetting Resin Conduit. Horizontal or Vertical installation.

**FRE COMPOSITES (2005) INC** — BreathSaver Brand Type XW Conduit and Type XW elbows

Cable Size, AWG/ kcmil	Minimum Raceway Trade Size, in.							
	Horizontal Installation: No. of Cables				Vertical Installation: No. of Cables			
	1	2	3	4	1	2	3	4
8	3/4	3/4	1	1	3/4	1	1-1/4	1-1/4
6	3/4	1	1-1/4	1-1/4	1	1-1/2	2-1/2	2-1/2
4	3/4	1	1-1/4	1-1/2	1-1/4	2	2-1/2	3
3	3/4	1-1/4	1-1/4	1-1/2	1-1/4	2	2-1/2	3
2	3/4	1-1/4	1-1/2	1-1/2	1-1/4	2-1/2	3	3
1	1	1-1/2	2	2-1/2	1-1/2	2-1/2	3-1/2	3-1/2
1/0	1	1-1/2	2-1/2	2-1/2	2	3	3-1/2	4
2/0	1-1/4	2	2-1/2	3	2	3	3-1/2	4
3/0	1-1/4	2	2-1/2	3	2-1/2	3-1/2	4	5

4/0	1-1/4	2-1/2	3	3	2-1/2	3-1/2	4	5
250	1-1/4	2-1/2	3	3	2-1/2	3-1/2	4	5
300	2	3	3-1/2	4	2-1/2	3-1/2	5	5
350	2	3	3-1/2	4	3	3-1/2	5	6
400	2	3	3-1/2	4	3	4	5	6
500	2-1/2	3	4	5	2-1/2	3-1/2	5	5
600	2-1/2	3-1/2	5	5	3	4	5	6
750	2-1/2	3-1/2	5	5	3	4	5	6

2A. **Raceway Coupling\*** — (Not Shown).

**FRE COMPOSITES (2005) INC** — BreathSaver Brand Type XW coupling. Trade size to correspond with the raceway size

3. **Fire Resistive Cables\*** — The hourly fire rating applies to cable passing completely through a fire zone and terminating a minimum of 12 inches beyond the fire rated wall or floor bounding the fire zone.

**DRAKA CABLETEQ USA INC** — Type RHW-2 Lifeline Brand of the following part numbers: G300 followed by 64, 65, 66, 67, 68, 69, 70, 71, 72, 73, 74, 75, 77, 78; or QLIFLINE followed by 300 or 400 followed by KCMIL. To be installed as described herein and in accordance with the manufacturer's installation instructions dated February 29, 2016, File R19359

4. **Supports** — (Figure 1) — Min 12 gauge, by 1-1/2 in. wide or 1-5/8 in wide, painted or unpainted, slotted steel channels with hemmed flange edges. Channel bottom with or without holes. Lengths of slotted steel channels 5 ft and less shall be secured to the wall or floor with a min of two 1/4 in. diameter (or larger) by 2-1/4 in. min long concrete screws, or 1/4 in. diameter (or larger) by 1-3/4 in. long min steel masonry anchors. One screw or anchor to be located at each end of the slotted steel channel. Lengths of slotted steel channel in excess of 5 ft require a min of three screws or anchors, one at each end of the channel and one centrally located within the length of the channel. The supports shall be spaced a maximum of 5 ft. OC. When installing cable(s) in vertical runs, the maximum distance of cable within raceway shall be 36 ft. between terminating points.

4A. **Trapeze-type Supports** — (Figure 2) — The raceways shall be installed on/from trapeze-type supports. The trapeze-type supports shall be secured from the surface of the floor. The supports shall be spaced a maximum of 5 ft. OC.

5. **Clamps** — Steel 1-1/4 in. wide two-piece single-bolt pipe clamps. Size to correspond with the outside diameter of the raceway and as follows: Trade size 3/4-2 in. conduit, min 14-gauge; Trade size 2-1/2 in. conduit, min 12-gauge; Trade size 3 in. and larger conduit, min 11-gauge.

\*Bearing the UL Classification Mark

Last Updated on 2016-11-08

[Questions?](#)

[Print this page](#)

[Terms of Use](#)

[Page Top](#)

© 2017 UL LLC

The appearance of a company's name or product in this database does not in itself assure that products so identified have been manufactured under UL's Follow-Up Service. Only those products bearing the UL Mark should be considered to be Certified and covered under UL's Follow-Up Service. Always look for the Mark on the product.

UL permits the reproduction of the material contained in the Online Certification Directory subject to the following conditions: 1. The Guide Information, Assemblies, Constructions, Designs, Systems, and/or Certifications (files) must be presented in their entirety and in a non-misleading manner, without any manipulation of the data (or drawings). 2. The statement "Reprinted from the Online Certifications Directory with permission from UL" must appear adjacent to the extracted material. In addition, the reprinted material must include a copyright notice in the following format: "© 2017 UL LLC".